

TYPICAL SETBACK DRIVEWAY

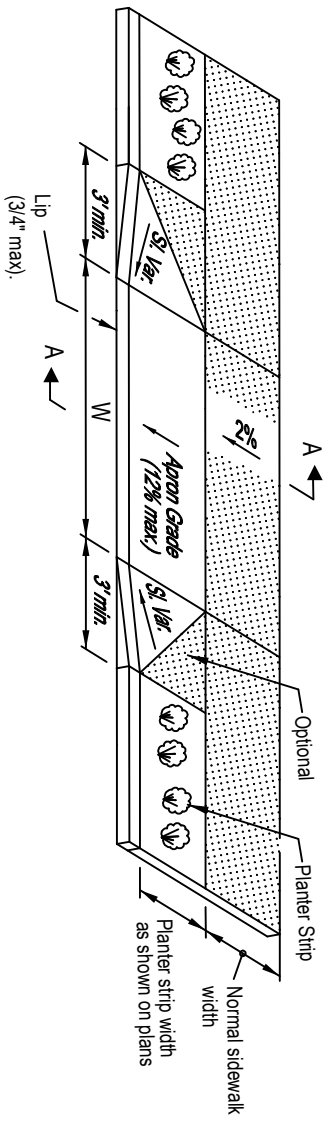

OPTIONAL LOWERED SIDEWALK

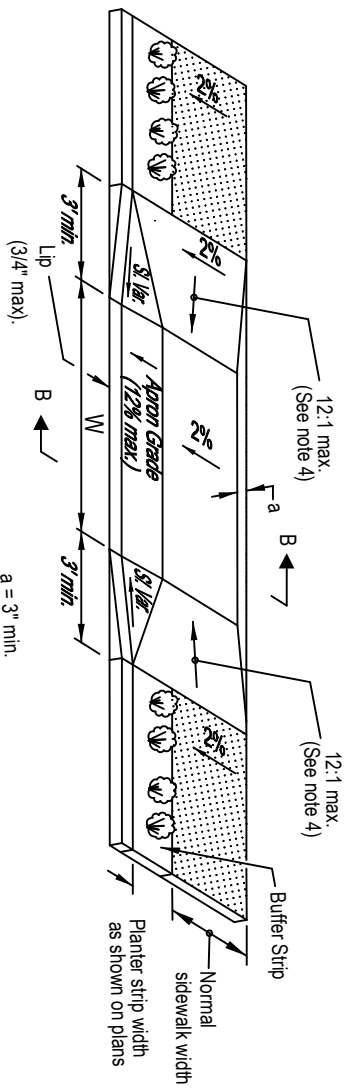

SECTION A-A

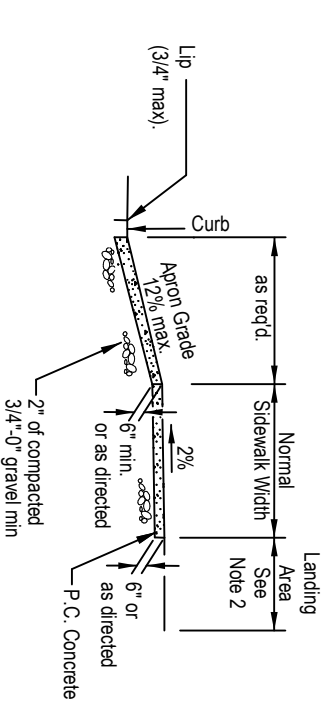

SECTION B-B

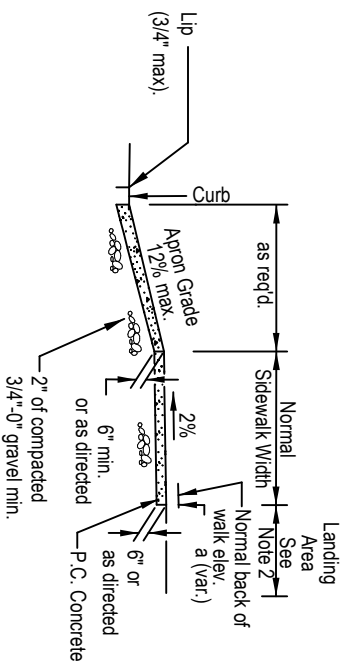

GENERAL NOTES:

1. 4' nom. width with slope of 2% is required through driveways.
2. Width of driveway (W) and length of landing area shall be as shown on plans or as directed.
3. Tooled joints are required at all driveway slope break lines.
4. Longitudinal slopes shown are relative to the running slope of the sidewalk.
5. Finish shall be medium broom, with no shine marks.

6. Maximum 6" square wire placed on 3" dobe blocks is required in commercial driveways.

7. Driveway approach and Curb & Gutter will be poured monolithically

NOTE: All material and workmanship shall be in accordance with the current Oregon Standard Specifications	
OREGON STANDARD DRAWINGS	
CITY OF HOOD RIVER	
SETBACK SIDEWALK	
DRIVEWAYS	
2002	
REVISIONS	DESCRIPTION
DATE	
12-02	City of Hood River Modifications

The selection and use of this Standard Drawing, while designed in accordance with generally accepted engineering principles and practices, is the sole responsibility of the user and should not be used without consulting a Registered Professional Engineer.